

AURORALIGHT

PROJECT: _____

SKU #: _____

TYPE: _____

GROUND STAKE

MGS001108

This ground stake is part of the most comprehensive ground stake offering available. Built with reinforced flanges for maximum durability; the exclusive wire feed channel speeds installation by guiding wire to exit out the side.

- Perfect for a variety of soil conditions
- Ideal for lightweight fixtures

DIMENSIONS	H8-1/2" x W2"
VOLTAGE	12V
MATERIAL	ABS Plastic

*For complete warranty terms, please visit: www.auroralight.com/warranty/

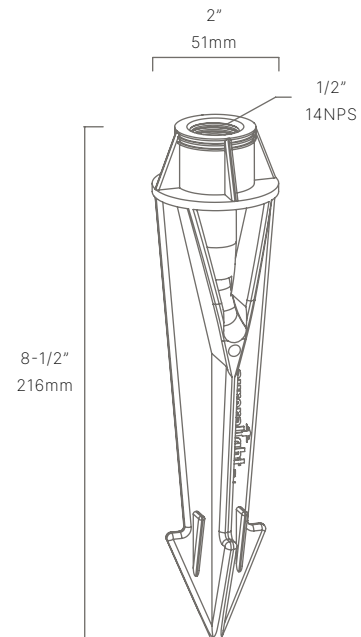
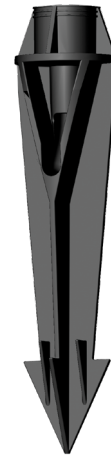

P. 760.931.2910

O. 2742 Loker Ave. W Carlsbad CA 92010

W. www.auroralight.com

MADE IN USA
WITH DOMESTIC & IMPORTED MATERIALS

